

# 672/673 SEMI-AUTOMATIC AND AUTOMATIC BEDKNIFE GRINDERS

## SPECIFICATIONS:

Power	115v, 50/60 cycle, Single phase, 15 amp
Weight	820 lbs (372 kg)
Grinding Wheel	6" (152 mm) Diameter Cupped Wheel
Carriage Base	3/4 HP AC grinding motor 3450 RPM; Cogged traverse belt with 38" travel capacity; Two 1.000 +/- .00025 ground/polished steel shafts; 90 Volt DC traverse motor

## STANDARD FEATURES:

- "Automatic Angle" Positioning
- "Automatic Alignment" Positioning
- Electromagnetic Bedknife Mounting System
- Built-in Diamond Dresser
- Self-Contained Flood Coolant System
- Supplemental Back-up Power Supply
- Grinding Motor Height Adjuster

## OPTIONAL EQUIPMENT:

- 220v to 110v Step-down Transformer
- Borazon Cup Grinding Wheel for Hardened Bedknives
- Replacement Flood Coolant Additive

Because Foley United is continually improving its products, specifications are subject to change without notice.

## DIMENSIONS:

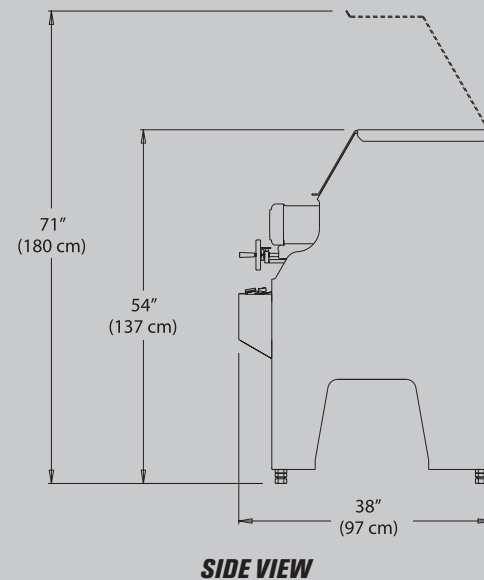
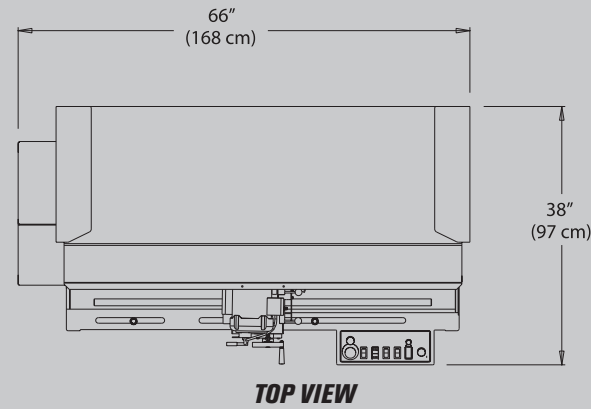

Distributed By:

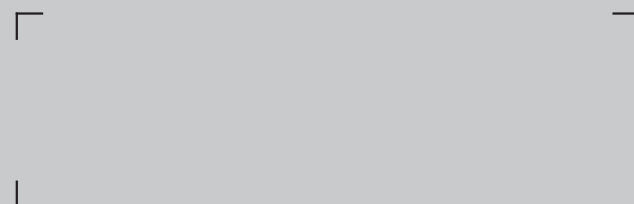

# 672/673 SEMI-AUTOMATIC AND AUTOMATIC BEDKNIFE GRINDERS



A Division of Foley-Belsaw  
River Falls, Wisconsin 54022  
[www.foleyunited.com](http://www.foleyunited.com)

THE HIGHEST QUALITY GRIND IN THE WORLD JUST GOT EASIER!

THE HIGHEST QUALITY GRIND IN THE WORLD JUST GOT EASIER!



# INDUSTRY WORKHORSE.

## 672 SEMI-AUTOMATIC AND 673 AUTOMATIC BEDKNIFE GRINDER

Foley United, the world leader in Reel Grinding Equipment since 1934, brings you the fastest and easiest to use bedknife grinders in the world—the 672 Semi-Automatic and the 673 Automatic Bedknife Grinders.

### Both Models Offer:

**An Innovative Bedknife Mounting System** that uses powerful electromagnets to hold the bed bar in place and Positive Gauge Stops to make set-up simple and fast. You can grind any bed bar arrangement without additional tooling.

**Fast Angle Set-up** that provides repeatability without recalibration. Set the Angle Stops once and the 672/673 will grind the same angle over and over. Changing from grinding the front face to the top face is as simple as pushing a button and watching as the powered Tool Bar rotates into the position.

**Operator Protection** provided by a sturdy metal hood with a clear polycarbonate window that retains the coolant mist and shields the operator. The Interlocking Switch prevents operation without the hood being totally closed. The supplemental power supply protects the operator in the event of a power outage, maintaining power to the electromagnets and holding the bed bar firmly in place.

**Easy-To-Use Controls.** The 672 uses a precision Hand Wheel to in-feed the grinding head while it automatically traverses back and forth across the bedknife. The 673 further automates the process by running one of the pre-set programs to automatically start the grinder, traverse the grinding head, in-feed the grinding head, and stop the grinding process.



**FLOOD COOLANT** controls dust, allows fast grinding time by controlling the bedknife temperature during the grind, and aids in producing a high quality surface finish.

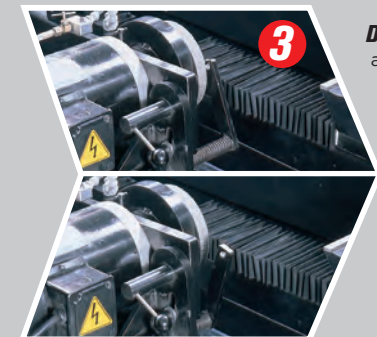

**DIAMOND WHEEL DRESSER** allows the operator to dress the grinding wheel. The permanently attached dresser stores easily out of the way during grinding and requires minimal adjustment for dressing.



**672 CONTROL** contains independent switches and a Traverse Speed Knob to control all grinder functions and meet all safety requirements, including an Emergency Stop Button. A green indicator light glows when the electromagnets are on.

**673 CONTROL** has the same features as the 672 Control plus an added Digital Readout to show the pre-set program number and a Program Select Button.

LEARN MORE: [www.foleyunited.com](http://www.foleyunited.com)



**FAST ANGLE SET-UP** provides repeatability without recalibration. By setting the Angle Stops once, the 672/673 can grind the same angle over and over. This is the market's fastest method of setting the desired angle.



**SUPPLEMENTAL POWER SUPPLY** is internal and easily accessible in the electronic drawer system built into the machine. This unit holds the bedknife in place and protects the operator in the event of an electrical supply interruption.



**ULTRA PRECISION TRAVERSE SYSTEM** is the key to straight bedknives over the life of the machine. Heat-treated, stress-relieved, and precision-machined, the traverse base utilizes a reliable belt drive system. These features combine to provide the precise foundation for the most accurate grind possible.

**673 AUTOMATIC BEDKNIFE GRINDER WITH AUTOMATED IN-FEED CONTROL** this control allows you to push a button and walk away as the 673 automatically in-feeds, traverses, and runs one of the pre-set programs.



**POWERED MOTION** of the tooling bar and mounting system simplifies and quickens the change from grinding the front to the top surface.



**BED BAR MOUNTING SYSTEM** allows the bed bar assembly to remain straight and stable throughout the grinding process without inducing stress.



**ALIGNMENT GAUGE** simplifies and virtually eliminates set-up time. The forward and upright position is used for alignment of the bedknife. After alignment, the gauge is stored in an out-of-the-way position.